

AXLE SEAL / TUBE SEAL AS SERIES / TT SERIES

PART #	COLOR	TUBING SIZE	HOUSING SIZE
AS9250	GOLD	2.500°	2.470°
AS9218	BLUE	2.560°	2.540°
AS9188	RED	2.625°	2.605°
AS9125	SILVER	2.750°	2.720°

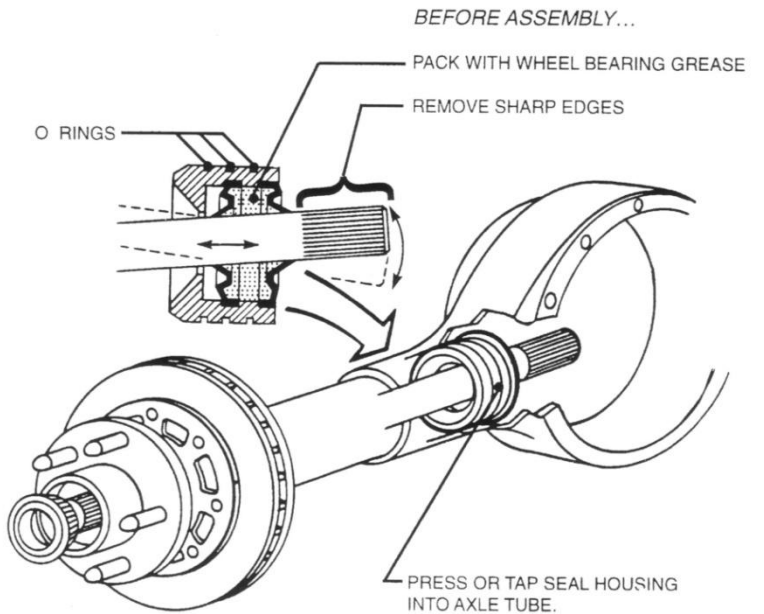

High cornering forces the gear lube out of the center section and down the axle tube leaving the ring and pinion high and dry! This billet aluminum seal has three O-rings that seal it to the axle tube and two bonded, heavy duty, neoprene inner seals designed to compensate for any amount of axle shaft run out.



PART #	COLOR	TUBING I.D.
TT9250	GOLD	2.500°
TT9218	BLUE	2.562°
TT9188	RED	2.625°
TT9125	SILVER	2.750°



This seal is installed in the tube to prevent the rear end lube from traveling up the tube and leaking out the bell. This aluminum seal has three O-rings and two grease resistant, high temperature seal on the inside.

